

1 keV to 30 keV

Small Spot Collimated Beam, Alignment during Operation, Higher Current Option

FOR USE IN:

- ▶ MBE Rheed studies
- ▶ Electron diffraction
- ▶ Space physics studies
- ▶ Gas electron fluorescence
- ▶ X-Ray generation
- ▶ Heating / melting / welding
- ▶ Vacuum physics experiments

FEATURES / OPTIONS:

- ▶ New modular design
- ▶ Internal alignment while operating
- ▶ Collimated beam
- ▶ Small spot option down to 100 μm
- ▶ Higher current option up to 1 mA
- ▶ Electrostatic focusing & deflection
- ▶ Computer / Remote control
- ▶ UHV compatible / bakeable
- ▶ Beam pulsing & blanking options
- ▶ User-replaceable firing units

The Kimball Physics EMG-4212 Electron Gun, with its matching EGPS-4212 Power Supply, is a multi-purpose modular Electron Gun with applications in many areas. The EMG-4212/ EGPS-4212 is a complete subsystem ready to attach to a user's vacuum system and turn on. The gun has the capability of producing a collimated, small spot or flood electron beam.

Beam current, beam divergence, and beam energy are all adjustable over wide ranges. The energy can be varied from 1 keV to 30 keV. The beam current and spot size range depend on the system option as shown in the table below. With the various refractory metal disc cathodes, the beam current is independently adjustable from 1 nA to 100 μA . With a small spot option using a lanthanum hexaboride cathode, the gun can deliver spots down to 100 μm . With a high current option, beam currents up to 1 mA can be obtained. Rastering is also available as an option.

The modular design of the EMG-4212 allows either the firing unit assembly or the lens assembly to be replaced. The firing unit cartridge (including the cathode, cathode-mount, and Wehnelt aperture) is user-replaceable without removing the entire gun from the vacuum chamber. The anode is also replaceable. The cathode to anode spacing is internally adjustable to vary perveance.

The gun features an adjustable cathode feedthrough assembly that allows the mechanical alignment of the firing unit with respect to the anode and the column. This alignment can be done in real time while the gun is operating at full voltage with beam on. Various stand-alone designs of Faraday cups are available.



EGPS-4212A Electron Gun Power Supply with FlexPanel controller



EMG-4212A Electron Gun with 4 1/2 CF mounting flange

UHV technology is used throughout. The gun can be run in vacuums from 10^{-11} torr up to 10^{-5} torr for the standard Ta disc cathode. The electron gun is bakable to 350°C with cables removed.

Several cathode types are available to provide different system options: standard tantalum disc cathodes (Ta), single-crystal lanthanum hexaboride (LaB_6 , small spot, high brightness, min. vacuum 1×10^{-7} torr), barium oxide discs (BaO, low light, low energy spread, min. vacuum 1×10^{-7} torr) and yttria-coated iridium discs (Y_2O_3 - Ir, rugged, vacuum up to 10^{-4} torr). With the exception of BaO, the cathodes are not damaged by repeated exposure to atmospheric gases or water vapor when cold.

Firing unit cartridges are user-replaceable, and used cartridges may be returned to the factory for rebuild. The electron gun itself may also be sent back to the factory for complete disassembly, cleaning, and rebuild of the firing unit assembly (including installation of a new cathode).

The EGPS-4212 Power Supply features a modular design with miniaturized power supply clusters, optically isolated signals, and the new FlexPanel digital interface controller. The included power supplies are Beam Energy, Focus, X,Y Deflection and optional Beam Blanker, as well as the floating Source/ECC and Grid supplies. The system includes a separate High Voltage Power Supply connected to and controlled by the EGPS-4212 (only for High Current option). A rastering option can be provided by an additional power supply unit, the Raster Generator Deflection Unit (RGDU), built into the main EGPS supply.

The new FlexPanel provides a digital display screen and a keypad for programming control on the front panel. Rear panel connectors allow remote /computer control and metering of all gun power supplies. An RS-232 serial port and an analog input/output connector are included on standard power supply units. All common computer interface bus types can be accommodated, by use of appropriate digital to analog converters. RS-422/485 conversion is possible.

An optional LabVIEW™ computer program designed for the EMG-4212 is available for remote computer control and metering. Software is available in two types: Using National Instrument DAQ boards and SCSI connectors on the EGPS-4212, or via a simple serial connector interface. The program provides a virtual panel of controls and real-time metering on the user's computer screen.

EMG-4212 ELECTRON GUN SPECIFICATIONS	
BEAM ENERGY	1 keV to 30 keV (Independently adjustable)
BEAM CURRENT	Standard: 10 nA to 100 μ A (Independently adjustable) Small Spot option: 1 nA to 10 μ A High Current option: 1 μ A to 1 mA
ENERGY SPREAD	Approx. cathode thermal spread, calculated Ta - 0.5eV Y ₂ O ₃ - 0.4eV BaO - 0.3eV LaB ₆ - 0.4eV
BEAM DIVERGENCE	Collimated beam or Flood beam
SPOT SIZE	Standard: 500 μ m to 25 mm Small Spot option: 100 μ m to 10 mm High Current option: 1.5 mm to 25 mm
WORKING DISTANCE	Typical: 150 mm. Range: 100 mm to 1000 mm
BEAM DEFLECTION	4 Pole Electrostatic: $\pm 2^\circ$ at 30 keV; scales larger at lower energies
PULSE CAPABILITY (using appropriate pulse generator, not included)	Optional Dual Grid Power Supply: pulse width 2 μ s to DC, rise/ fall 500 ns, rep rates to 5 kHz (TTL required) Note: with High Current option, Grid may not cut off beam at higher energies
BEAM BLANKING	Optional Blanker with TTL input: Pulse width 1 μ s to DC, rep rate to 5 kHz. *Not available with high current option.
BEAM UNIFORMITY	Gaussian
FIRING UNIT	Customer-replaceable Firing Unit Cartridge includes precision-aligned cathode and Wehnelt (G-1) assembly
CATHODE TYPES	Standard: Tantalum disc Optional: Lanthanum hexaboride (LaB ₆), Barium oxide (BaO), or Yttrium oxide (Y ₂ O ₃) With the exception of barium oxide, cathodes not harmed by repeated exposure to atmospheric gases while cold
INTERNAL GUN ALIGNMENT	Adjustable Feedthrough for mechanical alignment of firing unit while gun is operating
MOUNTING	Flange Multiplexer with a 4 1/2 inch CFF, including both tapped and clear mounting holes
INSERTION LENGTH	Standard: 51 mm
GUN DIMENSIONS	Gun length in vacuum: 51 mm sealing surface to end, 51 mm dia. Outside vacuum: 258 mm sealing surface to end of cable (313 mm with blanker)
FEEDTHROUGHS	Multi-pin brazed ceramic, threaded stainless steel shell
CABLES / CONNECTORS	Multi-conductor 30 kV high voltage fully ground-shielded cable, 20 kV focus cable, and low voltage deflection cable, with mating aluminum connectors, to connect gun and power supply. Standard lengths: 3 m, Optional: 5 m
MAXIMUM BAKEOUT	350°C with cables removed

EGPS-4212 ELECTRON GUN POWER SUPPLY SPECIFICATIONS	
OUTPUT	All necessary voltages to drive the EMG-4212 Electron Gun (in combination with H.V. Power Supply)
ENERGY SUPPLY STABILITY	<0.01% per hour with 0.05% rms ripple at full output
BEAM STABILITY	$\pm 0.1\%$ per hour with Emission Current Control or $\pm 10\%$ per hour after warm up without ECC
CONTROLS	FlexPanel controls: Energy, Source, Grid, Focus, X and Y Deflection, Emission Current Control, Optional Blanker Voltage
METERING	FlexPanel digital meters: Energy, Source Voltage, Source Current, Emission Current, Grid, Focus, X and Y Deflection, Blanker Voltage, Optional Beam Dump Current
COMPUTER/REMOTE CONTROL & METER	Power supplies: 0 to +10 V (-10 V to +10 V, deflection) Metering: 0 to +2 V (-2 V to +2 V, deflection) Standard 50-pin connector for analog input/output and RS-232 serial port (RS-422 or RS-485 available, if specified at time of order) Optional: SCSI metering and programming connectors
SOFTWARE	Standard configuration designed for RS-232 connections. Optional: National Instruments LabVIEW™ file, designed to run with computer DAQ boards NI PCI-6713 and PCIe-6341. SCSI interface
INPUT	115 VAC or 230 VAC, 50 to 60 Hz single phase, 250 VA
ENVIRONMENT	Temperature: 0 to 40°C, Relative humidity: 0 to 75% RH non condensing, Classified as a pollution degree 2, installation category (overvoltage category) II environment unit
DIMENSIONS (width x height x depth)	Approx: 17 in. x 7 in. x 22 in. excluding handles (425 mm x 172 mm x 560 mm); 19 in. rack mountable. HC supply extra

OPTIONAL RGDU-4A RASTER GENERATOR SPECIFICATIONS	
RASTER GENERATOR	Continuous control of X & Y Raster Amplitude, variable offset (Centering) and Frequency, with 0-10 kHz (X) and 0-100 Hz (Y) standard. All parameters controllable via RS-232, RS-422, RS-485, analog input, or computer control with LabVIEW™ software option.
DIMENSIONS	Adds approx. 2 in to height of standard EGPS supply



A typical lab set-up of a complete Kimball Physics system with power supplies, electron gun, and optional computer control system

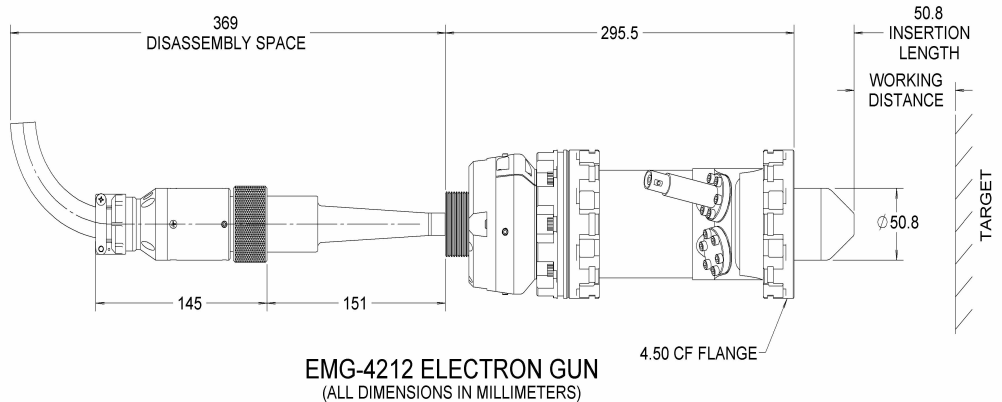

EMG-4212 ELECTRON GUN
(ALL DIMENSIONS IN MILLIMETERS)

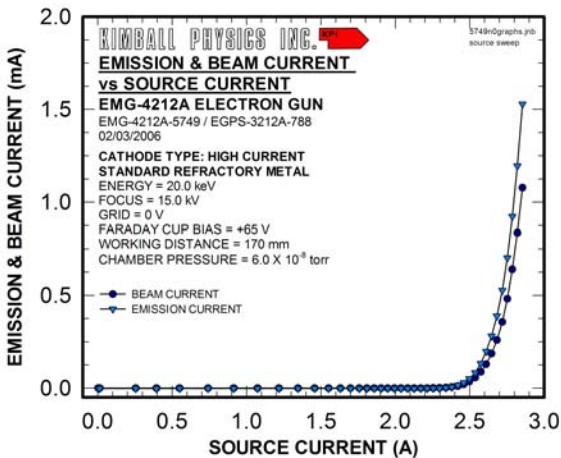

Typical performance; data for guidance only.

