

10 keV to 100 keV

High Energy Electron Beams, Two Lens System, High Currents up to 20 mA pulsed

FOR USE IN:

VACUUM PHYSICS EXPERIMENTS
PLASMA EXCITATION

FEATURES / OPTIONS:

HIGH BEAM CURRENTS UP TO 20mA
MAGNETOSTATIC FOCUSING
TWO - LENS SYSTEM
MAGNETOSTATIC DEFLECTION
PULSE CAPABILITY
DIFFERENTIAL PUMPING
AND OPTIONAL GATE VALVE
USER-REPLACEABLE FIRING UNITS

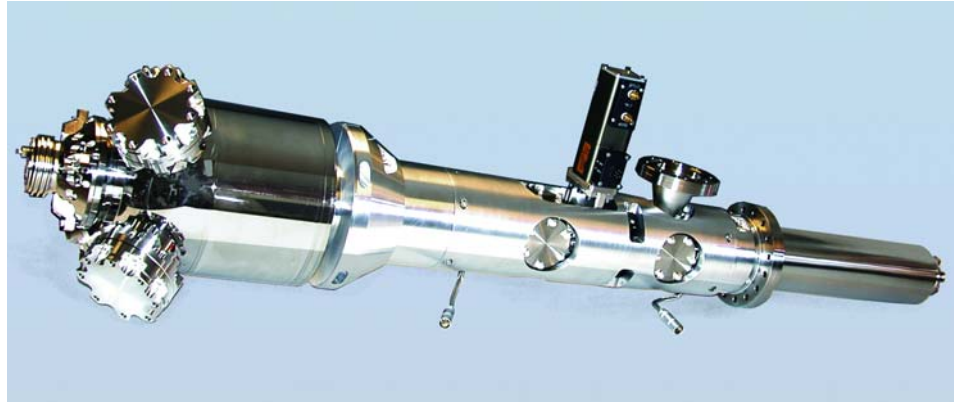

EGH-8202 Electron Gun with 6 CF mounting flange, differential pumping, and optional gate valve

The Kimball Physics EGH-8202 Electron Gun, with its matching EGPS-8202 Power Supply is a complete subsystem ready to attach to the user's vacuum system and turn on. It can deliver electrons over a very broad range of energies, currents and power. The EGH-8202 can be used in a variety of high power, pulsed applications in vacuum physics, such as plasma generation.

The gun uses an yttria-coated iridium cathode to generate a high energy, focusable electron beam. Both beam energy and beam current are independently adjustable over wide ranges, the energy from 10 keV to 100 keV, and current from 10 nA to 20 mA. The electron beam can be pulsed by an input signal to the control grid.

The adjustable optics of the gun can adapt to different divergences and different working distances. The spot size can be varied from 1 mm to 15 mm at the end of the gun. The working distance ranges from 0 mm (the end of the gun) to 1000 mm. Two magnetic focusing lenses and two magnetic centering deflection coils provide beam control with low aberration. In addition, the tetrode to second anode spacing is internally adjustable to change perveance.

The gun features an adjustable cathode feedthrough assembly that allows the mechanical alignment of the firing unit with respect to the anode and the column. This alignment can be done in real time while the gun is operating with beam on.

UHV technology is used throughout. The gun can be run in vacuums from 10^{-11} torr to 10^{-6} torr. The electron gun is bakeable to 200°C with cables removed; bakeout is limited by the magnetic focus and deflection coils. The Source region separately is bakeable to 350°C.

The EGH 8202 employs a high current, rugged yttria-coated iridium disc cathode. ($Y_2O_3 - Ir$). The cathode is not damaged by repeated exposure to atmospheric gases or water vapor when cold. In addition, the iridium cathode may survive a brief accidental loss of vacuum.

The gun design provides for differential pumping of the Source region. There is an optional gate valve after the first lens, as well as attachment for Turbo pumps on the Source chamber and on the other side of the valve.

The gun is usually mounted on a 6 inch CF flange and has 440 mm insertion distance. A 2" CF flange on end of the gun allows a user supplied foil to be mounted at the beam exit. Due to the high power beam produced by the EGH-8202, X-ray shielding is essential.

Firing units are user-replaceable without removing the entire gun from the vacuum chamber and, if the optional gate valve is installed, without breaking vacuum on the host vacuum system. Spare firing units can be purchased new, and used firing units may be returned to the factory for rebuild. Alternatively, the entire electron gun can be sent back to the factory for complete cleaning, rebuild, cathode replacement, and optional in-vacuum testing. Various stand-alone Faraday cup designs are available.

The Power Supply System for the EGH-8202 is composed of two separate units: the EGPS-8202 Electron Gun Power Supply, and an H.V. slave unit controlled by the EGPS-8202. The EGPS-8202 features a modular design with miniaturized power supply clusters, optically isolated signals, and the new FlexPanel digital interface controller. The included power supplies are Beam Energy, magnetic Lens, and magnetic X, Y Deflection, as well as the floating Source/ECC, Grid and First Anode supplies.

The FlexPanel provides a digital display screen and a keypad for programming control on the front panel. Rear panel connectors allow remote /computer control and metering of all gun power supplies. An RS-232 or RS-422/485 serial port and an analog input/output connector are included on standard power supply units. All common computer interface bus types can be accommodated, by use of appropriate digital to analog converters.

An optional LabVIEW™ computer program designed for the EGH-8202 is available for remote computer control and metering. Software is available in two types: Standard configuration is via a simple serial connector interface: Optional is using National Instrument DAQ boards and SCSI connectors on the EGPS-8202. The program provides a virtual panel of controls and real-time metering on the user's computer screen.

EGH-8202 ELECTRON GUN SPECIFICATIONS	
BEAM ENERGY	10 keV to 100 keV (Independently adjustable)
BEAM CURRENT	100 nA to 1 mA (Independently adjustable) Pulsed beam: up to 20 mA
ENERGY SPREAD	Approx. 0.4 eV cathode thermal spread, calculated
BEAM FOCUSING	Magnetostatic, 2 lens system
BEAM DIVERGENCE	Variable. Adjustable optics to adapt to different divergences and different working distances
SPOT SIZE	Range: 1 mm to 100 mm; 1 mm to 15 mm at end of gun
WORKING DISTANCE	0 to 1000 mm
BEAM DEFLECTION	Magnetostatic: $\pm 0.5^\circ$ at 100 keV
PULSE CAPABILITY	Optional Dual Grid Power Supply: pulse width 2 μ s to DC, rise/fall 500 ns, rep rates to 5 kHz w/ optional LabVIEW™ pulse generator or user's TTL pulser
BEAM BLANKING	None
BEAM UNIFORMITY	Gaussian
FIRING UNIT	Customer-replaceable Firing Unit Cartridge includes precision-aligned cathode, and Wehnelt (G-1) assembly. Entire firing unit also includes first anode
CATHODE TYPE	Yttrium oxide (Y_2O_3) Cathodes not harmed by repeated exposure to atmospheric gases while cold
INTERNAL GUN ALIGNMENT	Adjustable Feedthrough for mechanical alignment of firing unit while gun is operating
MOUNTING	6 inch CF flange, Optional two support brackets
DIFFERENTIAL PUMPING	Three 4½ inch ports for small pumps and two 2¼ inch ports for ionization gauges Optional in-line valve for isolation of Source chamber: VAT Mini UHV gate valve with double acting pneumatic actuator and position indicator, #01032-UE-0004 Optional pumps: Varian Turbo-V70 LP with controller Optional gauges: Granville-Phillips 354 Micro-Ion Module
INSERTION LENGTH	440 mm
GUN DIMENSIONS	Gun length: 1270 mm outside vacuum, sealing surface to end of cable connector Gun diameter: 335 mm at flange cluster on Source chamber, 203.2 mm dia Source chamber, 127 mm dia housing support tube
FEEDTHROUGHS	Multi-pin brazed ceramic, threaded aluminum-plated shell for main cable and stainless steel shell for others
CABLES / CONNECTORS	All high voltage fully ground-shielded cables with mating metal to metal connectors, to connect gun and power supply. Standard lengths: 3 m
MAXIMUM BAKEOUT	200°C with cables removed (200°C for magnetic Lens and Deflection coils, 350°C for Source chamber region)

EGPS-8202 ELECTRON GUN POWER SUPPLY SPECIFICATIONS	
OUTPUT	All necessary voltages to drive the EGH-8202 Electron Gun (in combination with H.V. Power Supply)
ENERGY SUPPLY STABILITY	<0.01% per hour with 0.05% rms ripple at full output
BEAM STABILITY	$\pm 0.1\%$ per hour with Emission Current Control or $\pm 10\%$ per hour after warm up without ECC
CONTROLS	FlexPanel controls: Energy, Source, Grid, 1st Anode, Emission Current Control, Lens1, Lens2, Deflection1 X&Y, Deflection2 X&Y.
METERING	FlexPanel digital meters: Energy, Source Voltage, Source Current, Emission Current, Grid Voltage, 1st Anode Voltage, Lens1 Current, Lens2 Current, Deflection1 X&Y Currents, Deflection2 X&Y Currents
COMPUTER/REMOTE CONTROL & METER	Power supplies: 0 to +10 V (-10 V to +10 V, deflection) Metering: 0 to +2 V (-2 V to +2 V, deflection) Standard 50-pin connector for analog input/output and RS-232 serial port (RS-232, RS-422 or RS-485 available, if specified at time of order) Optional: SCSI metering and programming connectors
INPUT	115 VAC or 230 VAC, 50 to 60 Hz single phase, 250 VA
ENVIRONMENT	Temperature: 0 to 40°C, Relative humidity: 0 to 75% RH non condensing, Classified as a pollution degree 2, installation category (overvoltage category) II environment unit
SOFTWARE	Standard configuration designed for RS-232 connections. Optional: National Instruments LabVIEW™ file, designed to run with computer DAQ boards PCI-6713 and PCIe-6341. SCSI interface
DIMENSIONS (width x height x depth)	Single unit, total approx: 17 in. x 5.3 in. x 22 in. excluding handles (425 mm x 135 mm x 560 mm); 19 in. rack mountable
DIMENSIONS H.V. Floating Supply	7 in. x 5 in. x 25 in. (152 mm x 127 mm x 635 mm); placed near gun

Typical performance;
data for guidance only.

